



# **SPEAKER SYSTEM**

**H-3  
H-3WP**

Please follow the instructions in this manual to obtain optimum results from this unit.  
We also recommend that you keep this manual handy for future reference.

## **TABLE OF CONTENTS**

<b>1. SAFETY PRECAUTIONS .....</b>	<b>2</b>
<b>2. GENERAL DESCRIPTION .....</b>	<b>3</b>
<b>3. FEATURES .....</b>	<b>3</b>
<b>4. HANDLING PRECAUTIONS .....</b>	<b>3</b>
<b>5. NOMENCLATURE AND DIMENSIONS .....</b>	<b>4</b>
<b>6. INSTALLATION</b>	
6.1. Contents.....	5
6.2. Installation Example (Using Two-Gang Electrical Box) .....	5
6.3. Installation Procedures .....	6
<b>7. REMOVING THE FRONT GRILLE .....</b>	<b>9</b>
<b>8. OUTDOOR USE (H-3WP ONLY)</b>	
8.1. Installation Precautions .....	10
8.2. Waterproofing the Base Frame .....	10
<b>9. REPAINTING THE FRONT GRILLE .....</b>	<b>10</b>
<b>10. PROTECTION CIRCUITRY INFORMATION .....</b>	<b>11</b>
<b>11. EQUALIZATION .....</b>	<b>11</b>
<b>12. SPECIFICATIONS .....</b>	<b>12</b>
Accessories .....	12

# 1. SAFETY PRECAUTIONS

- Be sure to read the instructions in this section carefully before use.
- Make sure to observe the instructions in this manual as the conventions of safety symbols and messages regarded as very important precautions are included.
- We also recommend you keep this instruction manual handy for future reference.

## Safety Symbol and Message Conventions

Safety symbols and messages described below are used in this manual to prevent bodily injury and property damage which could result from mishandling. Before operating your product, read this manual first and understand the safety symbols and messages so you are thoroughly aware of the potential safety hazards.



Indicates a potentially hazardous situation which, if mishandled, could result in death or serious personal injury.



Indicates a potentially hazardous situation which, if mishandled, could result in moderate or minor personal injury, and/or property damage.



### When Installing the Unit

- Install the unit only in a location that can structurally support the weight of the unit and the mounting bracket. Doing otherwise may result in the unit falling down and causing personal injury and/or property damage.
- Use the H-3WP in locations where the temperature is between  $-15$  and  $+50^{\circ}\text{C}$ . When installing in the snowy area, take appropriate measures to prevent snow from lying on the unit. If the ambient temperature exceeds  $-15$  or  $+50^{\circ}\text{C}$  or if the snow lies on the unit, the unit may fall, causing personal injuries.
- Use nuts and bolts that are appropriate for the wall's structure and composition. Failure to do so may cause the speaker to fall, resulting in material damage and possible personal injury.
- Tighten each nut and bolt securely. Ensure that the bracket has no loose joints after installation to prevent accidents that could result in personal injury.

### When the Unit is in Use

- Should the following irregularity be found during use, immediately switch off the power, disconnect the power supply plug from the AC outlet and contact your nearest TOA dealer. Make no further attempt to operate the unit in this condition as this may cause fire or electric shock.
  - If you detect smoke or a strange smell coming from the unit.
  - If water or any metallic object gets into the unit
  - If it is malfunctioning (no tone sounds.)



### When the Unit is in Use

- Do not operate the unit for an extended period of time with the sound distorting. This is an indication of a malfunction, which in turn can cause heat to generate and result in a fire.

## 2. GENERAL DESCRIPTION

TOA's H-3 and H-3WP are wall-mounted 2-way speakers featuring wide horizontal dispersion. The H-3 is designed for indoor use, and the H-3WP is designed for outdoor use.

**Note:** Protect the H-3WP from rain when installing. (Refer to p. 10 "Waterproofing the base frame.")

## 3. FEATURES

- Smooth curved surface blends in with the interiors of most modern buildings.
- Wide horizontal dispersion covers wide areas when mounted on the wall.
- Two 10 cm woofers feature a neodymium magnet which ensures powerful, low distortion low-frequency sound reproduction.
- 2.5 cm soft dome tweeter also employs a neodymium magnet for clear, low distortion high-frequency sound reproduction and high power-handling capability.
- Built-in crossover network circuitry features sharp cut-off characteristics that realize uniform energy radiation while suppressing unwanted input signals to the woofer or tweeter.
- Two lock tabs secure the enclosure to the supplied base frame. The base frame can be mounted directly to a 2-unit electrical box.
- A built-in matching transformer permits the speaker to be used for both high- and low-impedance applications. For low-impedance applications, either the 8  $\Omega$  terminal or 16  $\Omega$  terminal can be selected. Impedance can be easily changed from outside the unit.
- Detachable input connectors with dual positive and negative terminals for bridge connections.
- Enclosure is made of fire-resistant ABS resin (UL Standard 94V-0 Grade).
- Front grille is specially designed for ease of refinishing and repainting.

## 4. HANDLING PRECAUTIONS

- To clean, wipe the unit with a dry cloth. When the unit gets very dirty, use a cloth damped in a neutral detergent. Never use benzine, thinner or chemically-treated towel, as this could damage the unit's form or finish.
- Avoid using the H-3WP speaker on the beach because the speaker's life can be greatly shortened by sea breezes.

## 5. NOMENCLATURE AND DIMENSIONS

The illustrations assume that the front grille is mounted to the speaker.

(Unit: mm)

**[Front]**

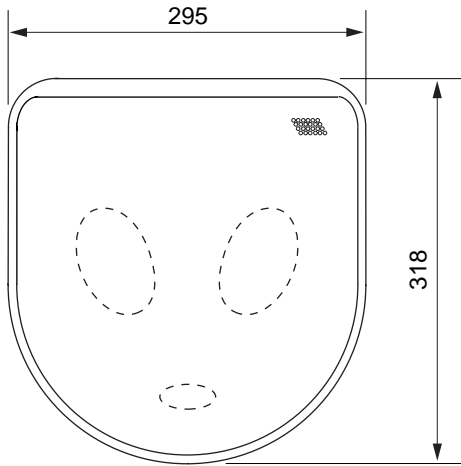

**[Side]**

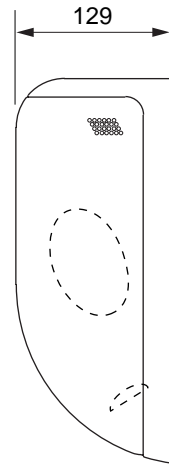

**[Rear]**

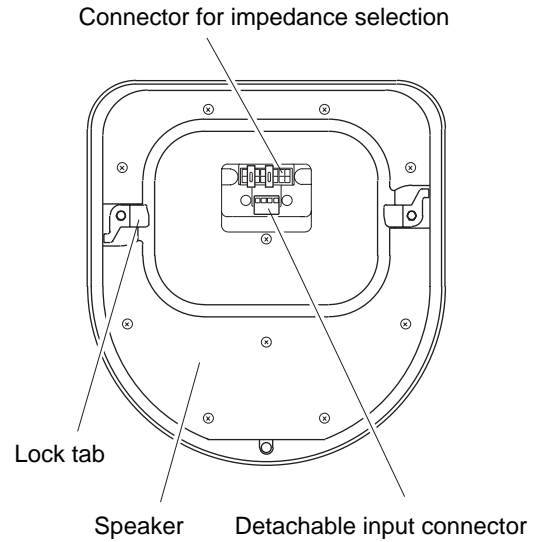

**[Bottom]**

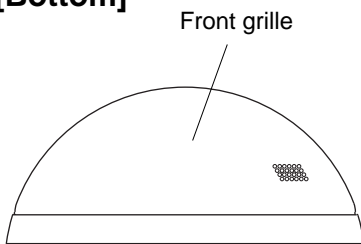

### • Base Frame (Accessory)

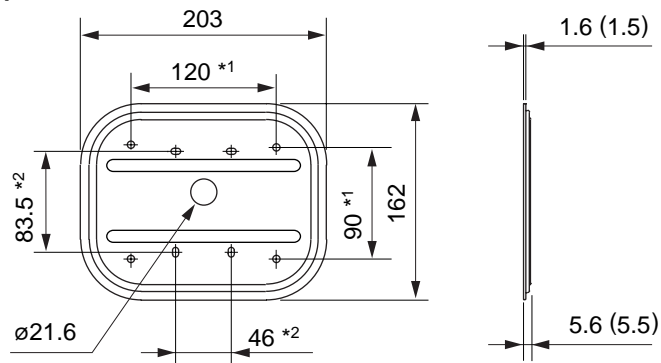

\*1 For mounting to a wall

\*2 For mounting to two-gang electrical box

Dimensions in parentheses ( ) apply to the H-3WP.

## 6. INSTALLATION

### 6.1. Contents

Check to be sure that the following components are available in a complete set before installation:

Speaker ..... 1

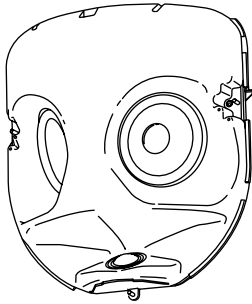

Front grille ..... 1

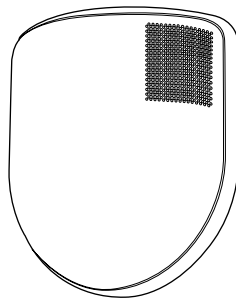

Base frame ..... 1

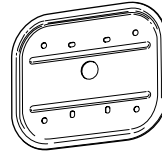

Screws and washers  
for electrical box

Machine screw  
M4 x 25 ..... 4



Unified screw  
(UNC-No.6-32) x 32 ..... 4



Plain washer ..... 4



Spring washer ..... 4



### 6.2. Installation Example (Using Two-Gang Electrical Box)

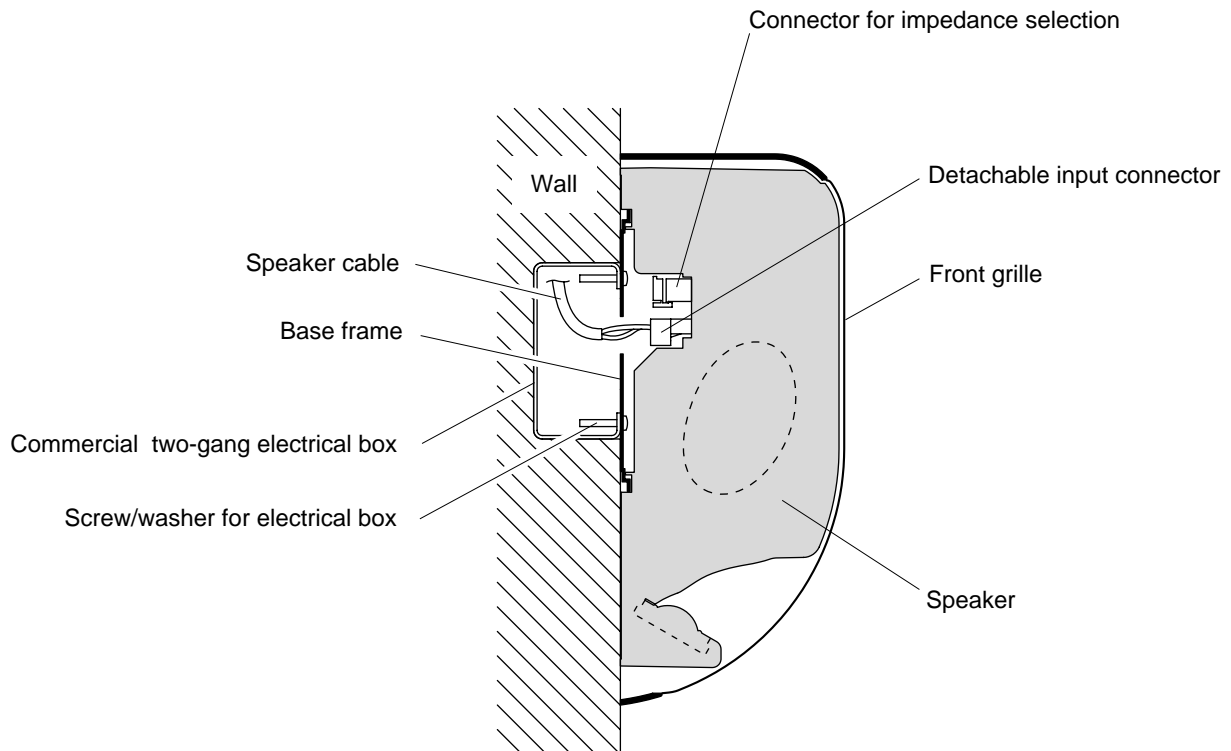

#### Note

To mount to two-gang electrical box, use either the supplied "M4 machine" or "Unified" screw depending on the type of the electrical box.

### 6.3. Installation Procedures

#### Step 1. Base frame mounting

- The base frame can be mounted on the wall directly or using a commercial two-gang electrical box.
- The base frame hole (21.6 mm in diameter) can also be used for conduit fitting.

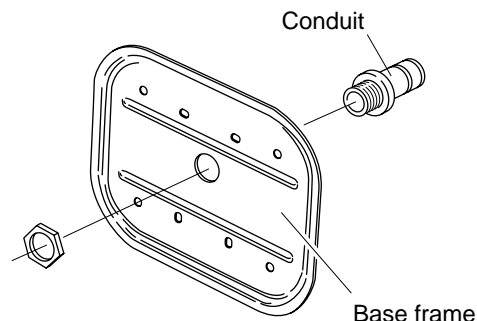

**Step 1-1.** Run the speaker cables from the wall through the base frame hole (21.6 mm in diameter), then strip the cables about 5 mm from the cable end.

- Usable cable: Solid or stranded cable (0.2 – 2.5 mm<sup>2</sup> corresponding to AWG24 – 14)

**Step 1-2.** Mount the base frame on the wall using four screws.

#### Notes

- The speaker cannot be mounted if the base frame is not properly positioned. Ensure that the base frame hole is situated on the upper side of the frame when mounted.
- Use nuts and bolts (not supplied with the unit for direct wall mounting) that are appropriate for the structure and composition of the wall.
- When using two-gang electrical box, use either the supplied "M4 machine" or "Unified" screw depending on the type of electrical box.
- Protect the H-3WP from rain when installing it outdoors. (Refer to p. 10 "Waterproofing the base frame.")

#### [Direct wall mounting]

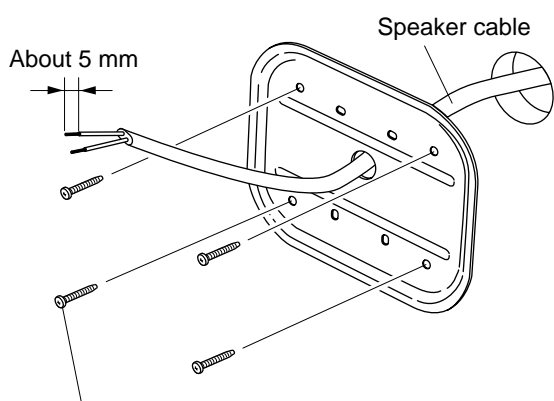

Use screws that are appropriate for the structure of the wall.

#### [Wall mounting by means of a commercial two-gang electrical box]

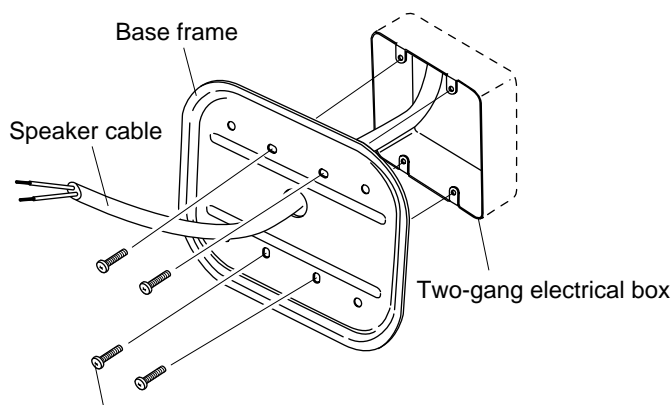

Use either the supplied M4 machine screw or Unified screw depending on the type of electrical box.

**Step 2. Wiring and impedance settings**

**Step 2-1.** Unplug the detachable input connector from the speaker socket, and loosen the screws of the terminal with a screwdriver.

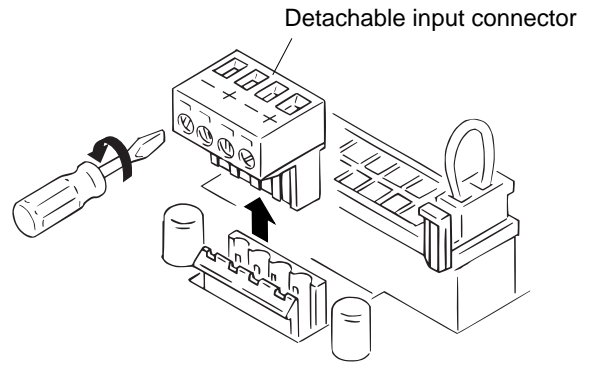

**Step 2-2.** Insert the stripped cable ends into the input connector, and retighten the terminal screws.

**[Single connection]**

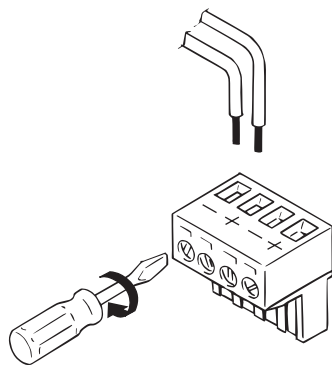

**[Bridge connection]**

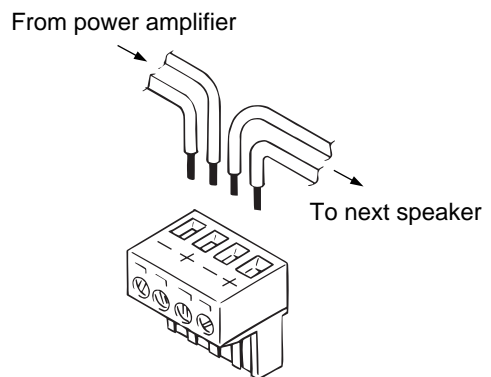

**Note**

When not bridging the connection, tighten the screws of unused terminals to prevent resonance noise.

**Step 2-3.** Attach two sockets to the impedance selection connector to select the desired impedance. The impedance is preset to 330 Ω (30 W for 100 V line and 15 W for 70 V line).

**[When selecting 8 Ω]**

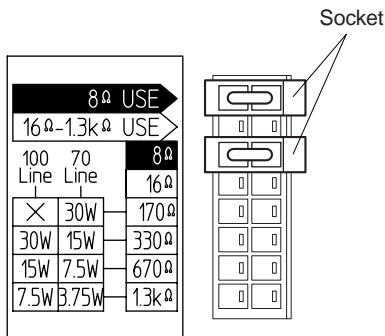

**[When selecting 16 Ω]**

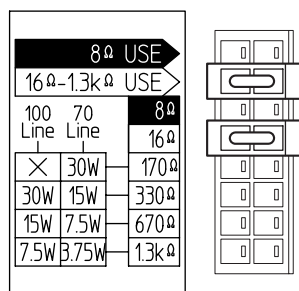

**[When selecting 330 Ω]  
(Preset by the factory)**

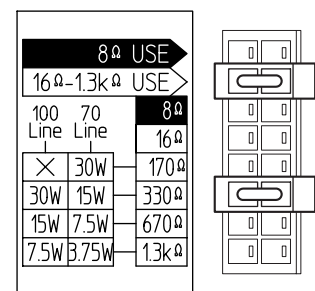

**Note**

The H-3 and H-3WP speakers are designed to be used for both 70 V and 100 V line applications. When using the 100 V line, do not select the "170 Ω" impedance, since the speaker itself or power amplifier may be damaged.

**Step 2-4.** Insert the detachable input connector into the speaker socket.

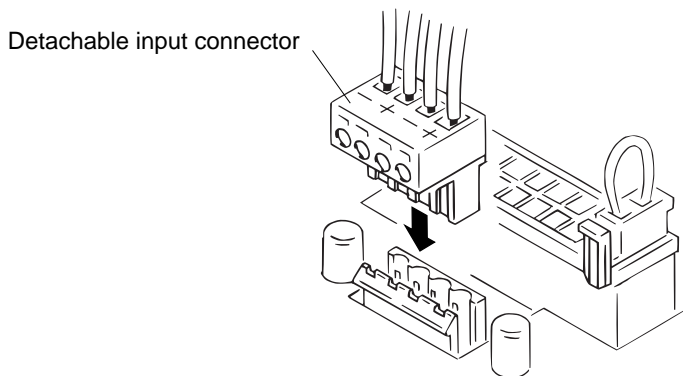

**Step 3.** Speaker and grille mounting

**Step 3-1.** Rotate the two speaker lock tabs away from their locking position on the edge of speaker.

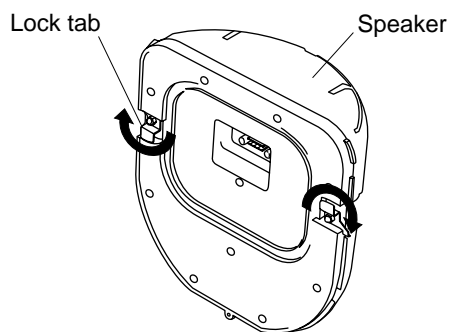

**Step 3-2.** After aligning the speaker with the base frame, rotate the two lock tabs back into position to clamp the speaker to the base frame. (Temporary fixing state)

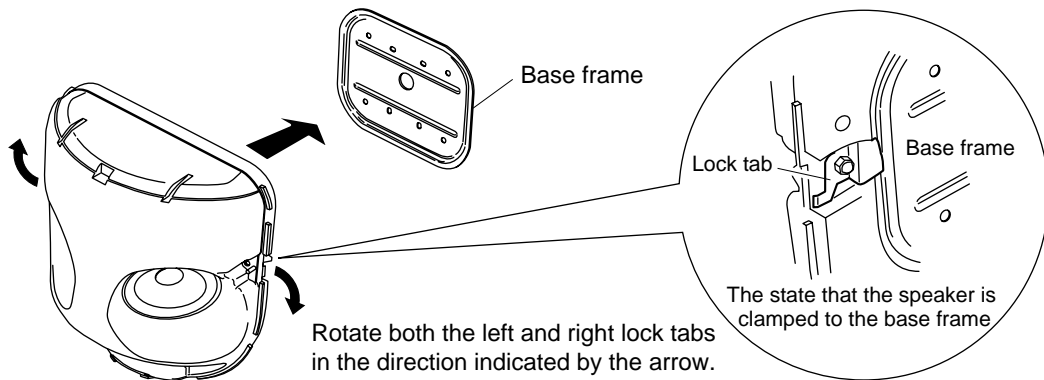

**Note**

When mounting the speaker, take care not to damage the diaphragms of both the woofers and tweeter.

**Step 3-3.** Position the speaker and tighten the two locking screws.

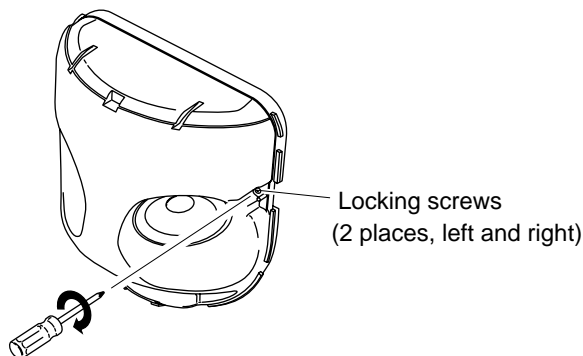



**Step 4.** Set the front grille to the speaker so that the three stud screws align with the corresponding stud receptacles, then push the grille onto the speaker.

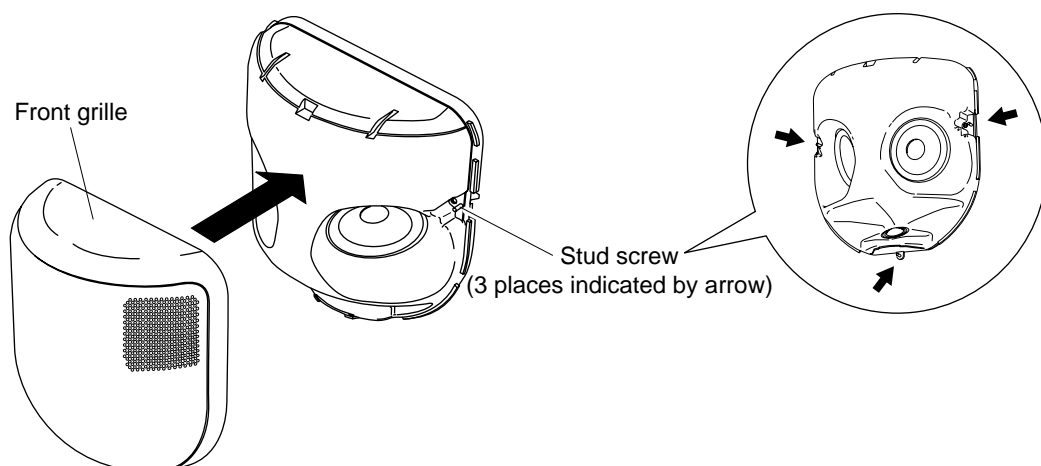

## 7. REMOVING THE FRONT GRILLE

**Step 1.** Insert a slotted screw driver into each of the three stud receptacles to widen a gap between the grille and wall.

**Step 2.** Pull the grille by hand from the three positions evenly and gradually.

### Caution

If you pull only from one or two of the three positions (stud receptacles), the front grille may be damaged. Be sure to pull from the three positions evenly and gradually.

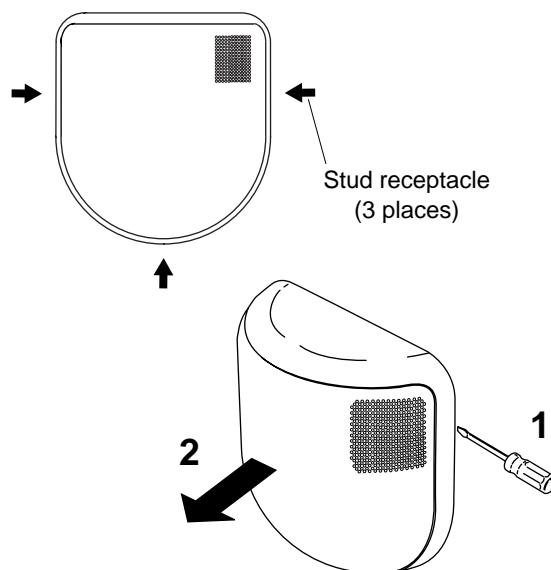

## 8. OUTDOOR USE (H-3WP ONLY)

### 8.1. Installation Precautions

- The H-3WP features drip-proof construction for permanent outdoor installation. However, do not dash water over it when cleaning as this may cause damage to the speaker components.
- When installing the H-3WP in a snowy area, protect the speaker so that it is not covered with snow.

### 8.2. Waterproofing the Base Frame

The H-3WP's base frame has a gasket for watertightness. To prevent water from getting into a gap between the base frame and wall, apply commercial caulking agent over the inside of the gasket before mounting the base frame.

#### Note

Take care not to apply too much caulking agent. If it spreads to the lock tab, the lock tab does not smoothly rotate and the speaker may not be mounted or detached.

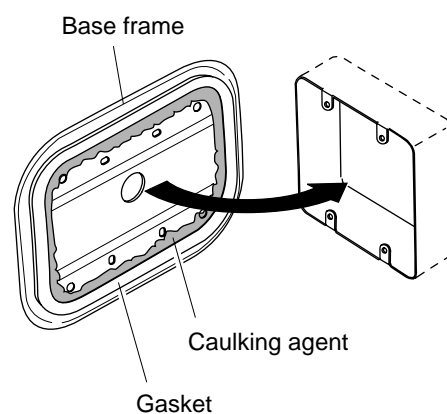

## 9. REPAINTING THE FRONT GRILLE

Follow the procedures below to change the color of the grille:

**Step 1.** Wipe dirt off the front grille with a soft cloth moistened with a detergent before painting. Do not use volatile liquids such as thinner.

**Step 2.** Uniformly spray a thin coating of paint over the grille changing the spraying positions gradually.

#### Notes

- Do not use a roller or brush to paint because the grille mesh could be clogged with paint.
- Use paint that is appropriate for the material of the front grille (grille and frame).
  - [H-3] Grille: Rolled steel plate
  - Frame: Fire-resistant ABS resin
  - [H-3WP] Grille: Stainless steel
  - Frame: Fire-resistant ABS resin
- Follow the instructions on the paint when painting.

**Step 3.** After the paint dries, repeat **Step 2** to repaint.

#### Note

Be sure to repeat **Step 2** at least twice. If you paint only once, the paint may not be uniformly applied or the grille mesh may be clogged.

## 10. PROTECTION CIRCUITRY INFORMATION

- The speaker's tweeter has built-in overload protection circuitry. (The woofer does not have the circuitry.)  
If there is an extremely high level input signal to the tweeter, the overload protection circuitry is activated and cuts off the signal input to the tweeter.
- A sudden drop of the sound volume level during speaker operation indicates that the overload protection circuitry has been activated. In such a case, reduce the amplifier volume and wait. The protection circuitry is automatically reset after approximately ten seconds. After the circuitry is reset, set the volume at a lower level than before.

### Caution

This overload protection circuitry does not completely protect the tweeter. Depending on the nature of the excessive signal applied to the speaker, there may be damage to the speaker before the protection circuitry can operate. Also, depending on the duration of the excessive input signal, the protection circuitry may be damaged and will not recover. Take special care that the excessive input is not applied to the speaker during use.

## 11. EQUALIZATION

- The H-3 and H-3WP speakers are designed to provide good quality sound without additional signal processing. However, by equalizing them as shown below, sounds can be made more powerful and intelligible.
- Using a digital signal processor, use the following equalization settings.

### [When not using a subwoofer]

Filter	Frequency	Gain	Q
HPF	63 Hz	—	0.707
PEQ	100 Hz	+9 dB	2.871
PEQ	220 Hz	-8 dB	2.871
PEQ	500 Hz	+5 dB	2.871
PEQ	5,000 Hz	+1.5 dB	0.305

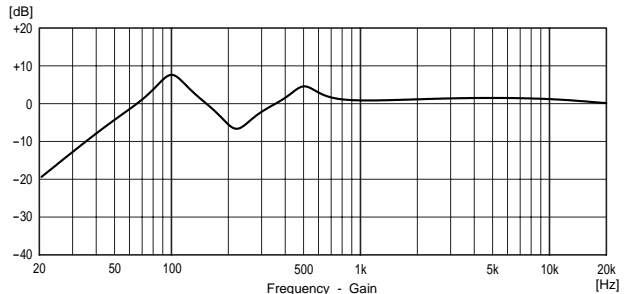

### [When using a subwoofer]

Filter	Frequency	Gain	Q
HPF	63 Hz	—	0.707
PEQ	100 Hz	+5 dB	2.871
PEQ	220 Hz	-8 dB	2.871
PEQ	500 Hz	+5 dB	2.871
PEQ	5,000 Hz	+1.5 dB	0.305

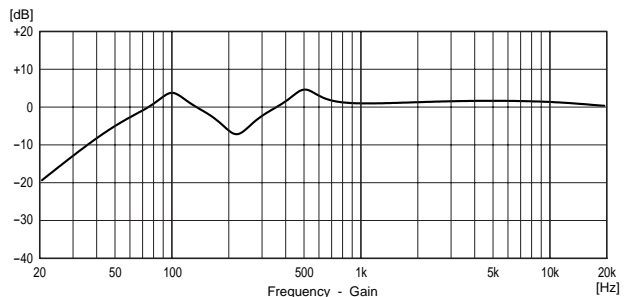

## 12. SPECIFICATIONS

Model No.	H-3		H-3WP	
Enclosure Type	Sealed type			
Power Handling	150 W (continuous program input, 8 Ω load) 50 W (continuous pink noise input, 8 Ω load) *			
Rated Input	30 W (16 Ω or high impedance)			
Rated Impedance	8 Ω, 16 Ω 70 V line: 170 Ω (30 W), 330 Ω (15 W), 670 Ω (7.5 W), 1.3 kΩ (3.75 W) 100 V line: 330 Ω (30 W), 670 Ω (15 W), 1.3 kΩ (7.5 W)			
Sound Pressure Level	89 dB (1 W, 1 m, installation in 1/2 free sound field)			
Frequency Response	100 – 20,000 Hz (–10 dB, installation in 1/2 free sound field)			
Crossover Frequency	4,000 Hz			
Speaker Element	Low frequency: 10 cm cone woofer (neodymium magnet) x 2 High frequency: 2.5 cm dome tweeter			
Input Terminal	Detachable screw terminal, (+)(–) 2 each (for bridge connection)			
Usable Cable	Solid or stranded cable: 0.2 – 2.5 mm <sup>2</sup> (corresponding to AWG24 – 14)			
Finish	Enclosure	Fire-resistant ABS resin (UL 94V-0), black		
	Front Grille	Rolled steel plate, white, paint	Stainless steel, white, paint	
	Grille Frame	Fire-resistant ABS resin (UL 94V-0), white, paint		
	Base Frame	Rolled steel plate	Stainless steel	
Dimensions	295 (w) x 318 (h) x 129 (d) mm			
Weight	3.3 kg (base frame included)			

\* Pink noise input (50 – 20,000 Hz), 24 hours

**Note:** The design and specifications are subject to change without notice for improvement.

### • Accessories

Base frame .....	1
Screws for electrical box mounting	
M4 x 25 .....	4
Unified (UNC-No.6-32) x 32 .....	4
Plain washer .....	4
Spring washer .....	4